

# MANUAL

## EXTA3\* Keyboard

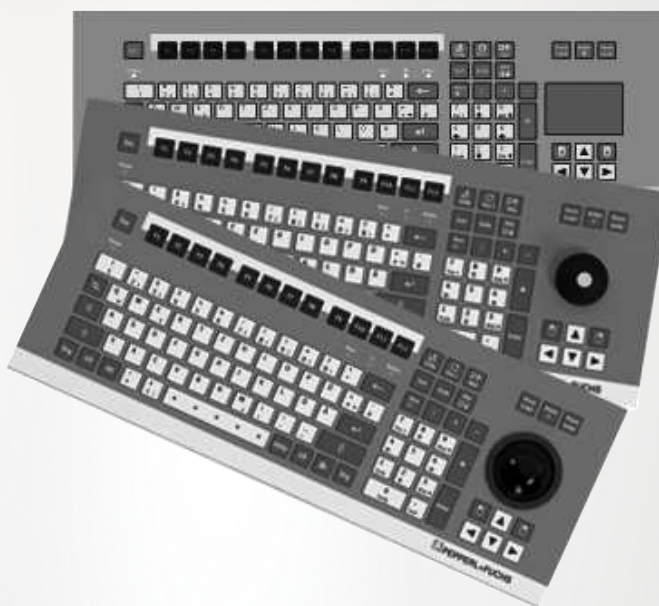

With regard to the supply of products, the current issue of the following document is applicable: The General Terms of Delivery for Products and Services of the Electrical Industry, published by the Central Association of the Electrical Industry (Zentralverband Elektrotechnik und Elektroindustrie (ZVEI) e.V.) in its most recent version as well as the supplementary clause: "Expanded reservation of proprietorship"

### **Worldwide**

Pepperl+Fuchs-Gruppe  
Lilienthalstr. 200  
68307 Mannheim  
Deutschland  
Telefon: +49 621 776 - 0  
E-Mail: [info@de.pepperl-fuchs.com](mailto:info@de.pepperl-fuchs.com)

### **North American Headquarters**

Pepperl+Fuchs Inc.  
1600 Enterprise Parkway  
Twinsburg, Ohio 44087  
USA  
Phone: +1 330 425-3555  
E-mail: [sales@us.pepperl-fuchs.com](mailto:sales@us.pepperl-fuchs.com)

### **Asia Headquarters**

Pepperl+Fuchs Pte. Ltd.  
P+F Building  
18 Ayer Rajah Crescent  
Singapore 139942  
Phone: +65 6779-9091  
E-mail: [sales@sg.pepperl-fuchs.com](mailto:sales@sg.pepperl-fuchs.com)  
<https://www.pepperl-fuchs.com>

<b>1</b>	<b>Safety</b> .....	<b>5</b>
1.1	General.....	5
1.2	Delivery, Transport, and Storage .....	5
1.3	Installation and Commissioning.....	5
1.4	Device Marking on the Keyboard .....	6
1.5	Housings and Surrounding Enclosures .....	7
1.5.1	Degree of Protection .....	7
1.6	Repair and Servicing .....	7
1.6.1	Servicing.....	7
1.7	Disposal .....	7
1.8	Use .....	7
1.8.1	Intended Use.....	7
1.8.2	Improper Use .....	8
1.9	Intended Use of the EXTA3 Keyboard.....	8
1.10	Symbols Used .....	8
<b>2</b>	<b>Product Specifications</b> .....	<b>10</b>
2.1	Function .....	10
2.2	EXTA3-**-*-K1*Keyboard.....	10
2.3	EXTA3-**-*-K3*Keyboard.....	11
2.4	EXTA3-**-*-K4*Keyboard.....	13
2.5	EXTA3-**-*-K6*Keyboard.....	15
2.6	EXTA3-**-*-K8*Keyboard.....	17
2.7	EXTA3-**-*-K9*Keyboard.....	19
2.8	Accessories .....	21
<b>3</b>	<b>Installation and Commissioning</b> .....	<b>23</b>
3.1	Connecting the Keyboard Connection Cable.....	23
3.2	Housing Design of the Keyboard .....	24
3.3	Replacing an EXTA3-K* Keyboard .....	28
3.3.1	Dismounting an EXTA3-K* Keyboard .....	28
3.3.2	Attaching EXTA3-K*Keyboard.....	29
<b>4</b>	<b>Appendix</b> .....	<b>31</b>
4.1	Chemical Resistance of Keyboard Foil.....	31
4.2	Anti Microbial Resistance of Keyboard Foil .....	31
4.3	Type Code .....	31



# 1 Safety

## 1.1 General

Responsibility for planning, assembly, commissioning, operation, maintenance, and dismantling lies with the plant operator.

Installation and commissioning of all devices may only be performed by trained and qualified personnel.

Protection of operating personnel and the system is not ensured if the product is not used in accordance with its intended use.

Observe the applicable laws and regulations regarding the intended use of the device. The devices are only approved for proper use for the intended purpose. Improper use will void any warranty and liability claims.

The corresponding datasheets, declarations of conformity, and/or EC-type examination certificates form an integral part of this document. The data sheet contains the electronic data of the EC-type-examination certificate.

These documents can be found at [www.pepperl-fuchs.com](http://www.pepperl-fuchs.com) or contact your local Pepperl+Fuchs representative.

## 1.2 Delivery, Transport, and Storage

Check the packaging and contents for damage.

Check if you have received every item and if the items received are the ones you ordered.

Keep the original packaging. Always store and transport the device in the original packaging.

Always store the device in a clean and dry location. Observe the permissible storage temperature (see datasheet).

## 1.3 Installation and Commissioning

Prior to mounting, installation, and commissioning of the device you should make yourself familiar with the device and carefully read the instruction manual.

### Installing alongside Intrinsically Safe Circuits

The intrinsically safe circuits of the devices may be installed in hazardous areas. In such cases, they must be securely isolated from all non-intrinsically safe circuits.

The intrinsically safe current circuits must be installed in accordance with the applicable installation regulations.

If intrinsically safe field devices are connected to the intrinsically safe circuits in associated devices, the respective maximum values of these field devices and the associated devices must be observed to ensure explosion protection (verification of intrinsic safety). EN 60079-14/IEC 60079-14 must be taken into account. The "National Foreword" (Nationale Vorwort) of DIN EN 60079-14/VDE 06165 Part 1 must be observed if the device is used in Germany.

The nameplate must not be removed.

The device must be de-energized during installation and servicing. The keyboard/mouse must not be connected to the supply voltage until the mounting and connection processes have been fully completed.

Individually accessible non-grounded metal parts can become electrostatically charged. The determined capacitance exceeds the required value according to IEC/EN 60079-0. The determined capacitance is specified in the technical data.

Information on electrostatic hazards can be found in the technical specification IEC/TS 60079-32-1.

## 1.4 Device Marking on the Keyboard



EXTA3-\*



Pepperl+Fuchs



68307 Mannheim, Germany

www.pepperl-fuchs.com

### Further Marking According to ATEX

EXTA3-A1-*
Pepperl+Fuchs Group 68307 Mannheim, Germany
PF 11 CERT 1918X
 II 3G Ex ic IIC T4 Gc
 II 3D Ex ic IIIB T135°C Dc
Ambient temperature: -20 °C ... +50 °C EXTA3-K3, EXTA3-K8: 0 °C ... 50 °C (32 °F ... 122 °F)

EXTA3-D2-*
Pepperl+Fuchs Group 68307 Mannheim, Germany
PF 11 CERT 1918X
 II 3G Ex ic IIC T4 Gc
 II 3D Ex ic IIIB T135°C Dc
Class I Division 2 Groups A, B, C, D Class I Zone 2 Group IIC
Ambient temperature: -20 °C ... +50 °C EXTA3-K8: 0 °C ... 50 °C (32 °F ... 122 °F)

EXTA3-D4-*
Pepperl+Fuchs Group 68307 Mannheim, Germany
PF 11 CERT 1918X
 II 3G Ex ic IIC T4 Gc
 II 3D Ex ic IIIB T135°C Dc
Class I Division 2 Groups A, B, C, D Class II Division 2 Groups F, G Class III Class I Zone 2 Group IIC Class II Zone 22 Group IIIB Class III Zone 22 Group IIIA
Ambient temperature: -20 °C ... +50 °C EXTA3-K8: 0 °C ... 50 °C (32 °F ... 122 °F)

## Applied Standards and Directives for EXTA3-\*

### EXTA3 Membrane Keyboard with Mouse

<b>Directive conformity</b>	
Electromagnetic compatibility	
Directive 2014/30/EU	EN 61326-1:2013
<b>Explosion protection</b>	
Directive 2014/34/EU	EN 60079-0:2012+A11:2013, EN 60079-11:2012
UL	Listing and recognition under file E190294
Control Drawing	116-0357C

## 1.5 Housings and Surrounding Enclosures

### 1.5.1 Degree of Protection

To ensure the degree of protection:

- The housing must not be damaged, distorted or corroded.
- All seals must be undamaged and correctly fitted.
- All screws of the housing/housing cover must be tightened with the appropriate torque.
- All cable glands must be suitably sized for the incoming cable diameters.
- All cable glands must be tightened with the appropriate torque.
- All unused cable glands must be sealed and closed with appropriate sealing plugs or stopping plugs.

### 1.6 Repair and Servicing

The device must not be repaired, changed, or manipulated. In case of failure, always replace the device with an original device.

#### 1.6.1 Servicing

If keyboards and mouse devices are used as parts of a system, standards, guidelines, or legal requirements may exist that stipulate regular system tests.

Keyboard functionality should be checked at least twice a year or more frequently if the keyboard is subject to difficult conditions.

Do not clean the keyboard with corrosive liquids.

Any contamination can cause the keyboard to malfunction or completely fail.

### 1.7 Disposal

The devices and the packaging material must be disposed of in accordance with the current applicable statutes and regulations in the respective country.

The devices do not contain any batteries that require separate disposal.

## 1.8 Use

### 1.8.1 Intended Use

The device is only approved for appropriate and intended use. Ignoring these instructions will void any warranty and absolve the manufacturer from any liability.

The device must only be operated in the specified ambient temperature range and at the specified relative humidity without condensation.

When using stranded conductors, crimp wire end ferrules on the conductor ends.

### 1.8.2 Improper Use

Protection of the personnel and the plant is not ensured if the device is not used according to its intended use.

## 1.9 Intended Use of the EXTA3 Keyboard

EXTA3 is a PC keyboard with an optional operating element for mouse functions (capacitive or resistive touch pad, mechanical and optical trackball mouse, joystick). The keyboard has USB interfaces for intended use in hazardous areas, Class I/Division 2, Class II, Division 2, and ATEX Zone 2 and Zone 22 areas according to ATEX Directive 2014/34/EU and IECEx. The USB interfaces of the keyboard and the operating element for mouse functions are separate, intrinsically safe circuits. Both intrinsically safe circuits are routed to the outside via one or two separate connection cables. The connection cable corresponds to type "B" in accordance with IEC 60079-14, Section 12.2.2.8. The cable must be secured and protected effectively against damage. The EXTA3 keyboard must not be installed in locations where corrosive media are used.

To prevent discharges, the keyboard may only be installed in areas with a low risk of strong electrostatic charges caused by dust. To prevent electrostatic charge, foils must not cover or be stuck onto the keyboard.

The keyboard must not be exposed to direct sunlight.

When connecting keyboard EXTA3 to a VisuNet RM/PC, ensure that the USB connection is not changed during operation. The keyboard cable must be connected when it is in a de-energized state.

If circuits with type of protection Ex i are operated with non-intrinsically safe circuits, they must no longer be used as circuits with type of protection Ex i.

Standalone applications require an I.S. barrier based on the Entity concept. Pepperl+Fuchs' model number for this I.S. barrier is SK-PC-D2-UU1-10-HS.

## 1.10 Symbols Used

### Safety-Relevant Symbols



#### Danger!

This symbol indicates an imminent danger.

Non-observance will result in personal injury or death.



#### Warning!

This symbol indicates a possible fault or danger.

Non-observance may cause personal injury or serious property damage.





---

**Caution!**

This symbol indicates a possible fault.

Non-observance could interrupt the device and any connected systems and plants, or result in their complete failure.

---

**Informative Symbols**

---

**Note**

This symbol brings important information to your attention.

---



---

**Action**

This symbol indicates a paragraph with instructions. You are prompted to perform an action or a sequence of actions.

## 2 Product Specifications

### 2.1 Function

The EXTA3 keyboard is a keyboard/mouse combination with USB interfaces that is available in different versions. The intrinsically safe keyboards contain different mouse systems.

The external dimensions are the same for all versions. The keyboards are intended for panel mounting or installation in housing.

EXTA3 is supplied with an 8-pin cordset.

### 2.2 EXTA3-\*\*-\*-K1\*Keyboard

Keyboard without mouse system





#### EXTA3-\*\*-\*-K1\*

General data	
Type	Keyboard without mouse system
Compatible components	SK-PC-D2-UU1-10-HS
Power supply	
Rated voltage	Ex i, via data line
Indicators/operating elements	
Keyboard	105 input keys Keyboard layout: US International (other keyboard layouts on request)
Directive conformity	
Electromagnetic compatibility	
Directive 2004/108/EC	EN 61000-4-2: 2009, EN 61000-4-3: 2006 + A1: 2008, EN 61000-4-4: 2004, EN 61000-4-6: 2009, EN 55011: 2009, EN 61000-6-2: 2005, EN 61000-6-4: 2007, EN 61326-1: 2006
Conformity with standards	
Degree of protection	IP66 (front) Type 4X

547507 2019-09

Ambient conditions	
Operating temperature	-20 °C ... 50 °C (-4 °F ... 122 °F)
Storage temperature	-10 °C ... 70 °C (14 °F ... 158 °F)
Relative humidity	Max. 85 %, not condensing (48 h endurance test)

Mechanical data	
Material	Anodized aluminum, polyester film
Weight	1.2 kg
Dimensions	Desktop housing: 559.3 mm x 254.6 mm x 44.5 mm (22.02 x 10.02 x 1.75) Panel mounting: 491.4 mm x 186.8 mm x 45 mm (19.35 x 7.35 x 1.77)
Opening dimensions	483 mm x 178.2 mm (19.01 x 7.01)
	1.8 m
Note	The limited energy barrier (SK-PC-D2-UU1-10-HS) is required when using this product.

Data for use in hazardous areas		
Certificate	PF II CERT 1918X	
Marking	 II 3GEx ic IIC T4 Gc  II 3D EX ic IIB T135 °C Dc	
Input		
Voltage	$U_i$	5.4 VDC
Current	$i_i$	240 mA
Internal capacitance	$C_i$	24 $\mu$ F
Internal inductance	$L_i$	Negligible
Directive conformity		
Directive 94/9/EC	EN 60079-0: 2009 EN 60079-11: 2007	

International approvals	
UL approval	cULus (E190294)
Approved for	Class I, Division 2, Groups A, B, C, D, T4 Class II, Division 2, F, G

## 2.3 EXTA3-\*\*-\*-K3\*Keyboard

Keyboard with mechanical trackball to control the mouse cursor.

The function of the left and right mouse buttons is performed by two separate buttons below the trackball.



### EXTA3-\*\*-\*-K3\*

General data	
Type	Keyboard with mechanical trackball
Compatible components	SK-PC-D2-UU1-10-HS

Power supply	
Rated voltage	Ex i, via data line

Indicators/operating elements	
Keyboard	105 input keys Keyboard layout: US International (other keyboard layouts on request)
Trackball	
Diameter	50 mm
Material	Phenolic resin (black)
Driver	Microsoft Mouse®, USB



Interface	
Interface type	USB

Directive conformity	
Electromagnetic compatibility	
Directive 2014/30/EU	EN 61326-1:2013
Explosion protection	
Directive 2014/34/EU	EN 60079-0:2012 + A11:2013, EN 60079-11:2012

Conformity with standards	
Degree of protection	IP65 if trackball is inactive. Undefined when moving. Type 4X

Ambient conditions	
Operating temperature	-20 °C ... 50 °C (-4 °F ... 122 °F)
Storage temperature	-20 °C ... 70 °C (-4 °F ... 158 °F)
Relative humidity	Max. 85 %, not condensing (48 h endurance test)

Mechanical data	
Material	Anodized aluminum, polyester film
Weight	1.2 kg
Dimensions	Desktop housing: 559.3 mm x 254.6 mm x 44.5 mm (22.02 x 10.02 x 1.75) Panel mounting: 491.4 mm x 186.8 mm x 45 mm (19.35 x 7.35 x 1.77)
Opening dimensions	483 mm x 178.2 mm (19.01 x 7.01)
Cable length	1.8 m
Note	The limited energy barrier (SK-PC-D2-UU1-10-HS) is required when using this product.

Data for use in hazardous areas		
Certificate	PF II CERT 1918X	
Marking	 II 3GEx ic IIC T4 Gc  II 3D EX ic IIB T135 °C Dc	
Input		
Voltage	$U_i$	5.4 VDC
Current	$i_i$	240 mA
Internal capacitance	$C_i$	24 $\mu$ F
Internal inductance	$L_i$	Negligible

International approvals	
UL approval	cULus (E190294)
Approved for	Class I, Division 2, Groups A, B, C, D, T5 Class II, Division 2, F,G T5

## 2.4 EXTA3-\*\*-\*-K4\*Keyboard

Keyboard with integrated capacitive touch pad to control the mouse cursor.

The function of the left and right mouse buttons is performed by two separate buttons below the touch pad.



### EXTA3-\*\*-\*-K4\*

General data	
Type	Keyboard with capacitive touch pad
Compatible components	SK-PC-D2-UU1-10-HS

Power supply	
Rated voltage	Ex i, via data line

Indicators/operating elements	
Keyboard	105 input keys Keyboard layout: US International (other keyboard layouts on request)
Touch pad	
Sensing principle	Capacitive
Resolution	40 Pts./mm
Dimensions	66 mm x 50 mm
Driver	Microsoft Mouse®, USB

Interface	
Interface type	USB



Directive conformity	
Electromagnetic compatibility	
Directive 2014/30/EU	EN 61326-1:2013
Explosion protection	
Directive 2014/34/EU	EN 60079-0:2012 + A11:2013, EN 60079-11:2012

547507 2019-09

Conformity with standards	
Degree of protection	IP66 (front) Type 4X

Ambient conditions	
Operating temperature	-20 °C ... 50 °C (-4 °F ... 122 °F)
Storage temperature	-20 °C ... 70 °C (-4 °F ... 158 °F)
Relative humidity	Max. 85 %, not condensing (48 h endurance test)

Mechanical data	
Material	Anodized aluminum, polyester film
Weight	1.2 kg
Dimensions	Desktop housing: 559.3 mm x 254.6 mm x 44.5 mm (22.02 x 10.02 x 1.75) Panel mounting: 491.4 mm x 186.8 mm x 45 mm (19.35 x 7.35 x 1.77)
Opening dimensions	483 mm x 178.2 mm (19.01 x 7.01)
Cable length	1.8 m
Note	The limited energy barrier (SK-PC-D2-UU1-10-HS) is required when using this product.

Data for use in hazardous areas		
Certificate	PF II CERT 1918X	
Marking	 II 3GEx ic IIC T4 Gc  II 3D EX ic IIB T135 °C Dc	
Input		
Voltage	$U_i$	5.4 VDC
Current	$i_i$	240 mA
Internal capacitance	$C_i$	24 $\mu$ F
Internal inductance	$L_i$	Negligible

International approvals	
UL approval	cULus (E190294)
Approved for	Class I, Division 2, Groups A, B, C, D, T4 Class II, Division 2, F, G
Control Drawing	116-0357B

## 2.5 EXTA3-\*\*-\*-K6\*Keyboard

Keyboard with joystick to control the mouse cursor.

The function of the left and right mouse buttons is performed by two separate buttons below the joystick.



### EXTA3-\*\*-\*-K6\*



General data	
Type	Keyboard with joystick
Compatible components	SK-PC-D2-UU1-10-HS
Power supply	
Rated voltage	Ex i, via data line
Indicators/operating elements	
Keyboard	105 input keys Keyboard layout: US International (other keyboard layouts on request)
Joystick	
Driver	Microsoft Mouse®, USB
Interface	
Interface type	USB
Directive conformity	
Electromagnetic compatibility	
Directive 2014/30/EU	EN 61326-1:2013
Explosion protection	
Directive 2014/34/EU	EN 60079-0:2012 + A11:2013, EN 60079-11:2012
Conformity with standards	
Degree of protection	IP66 (front) Type 4X

547507 2019-09



Ambient conditions	
Operating temperature	-20 °C ... 50 °C (-4 °F ... 122 °F)
Storage temperature	-20 °C ... 70 °C (-4 °F ... 158 °F)
Relative humidity	Max. 85 %, not condensing (48 h endurance test)

Mechanical data	
Material	Anodized aluminum, polyester film
Weight	1.2 kg
Dimensions	Desktop housing: 559.3 mm x 254.6 mm x 44.5 mm (22.02 x 10.02 x 1.75) Panel mounting: 491.4 mm x 186.8 mm x 45 mm (19.35 x 7.35 x 1.77)
Opening dimensions	483 mm x 178.2 mm (19.01 x 7.01)
Cable length	1.8 m
Note	The limited energy barrier (SK-PC-D2-UU1-10-HS) is required when using this product.

Data for use in hazardous areas		
Certificate	PF II CERT 1918X	
Marking	 II 3GEx ic IIC T4 Gc  II 3D EX ic IIB T135 °C Dc	
Input		
Voltage	$U_i$	5.4 VDC
Current	$i_i$	240 mA
Internal capacitance	$c_i$	24 $\mu$ F
Internal inductance	$L_i$	Negligible

International approvals	
UL approval	cULus (E190294)
Approved for	<b>EXTA3-D2:</b> Class I Division 2 Groups A, B, C, D Class I Zone 2 Group IIC <b>EXTA3-D4:</b> Class I Division 2 Groups A, B, C, D Class II Division 2 Groups F, G Class III Class I Zone 2 Group IIC Class II Zone 22 Group IIIB Class III Zone 22 Group IIIA
Control Drawing	116-0357B

## 2.6 EXTA3-\*\*-\*-K8\*Keyboard

Keyboard with optical trackball to control the mouse cursor.

The function of the left and right mouse buttons is performed by two separate buttons below the trackball.

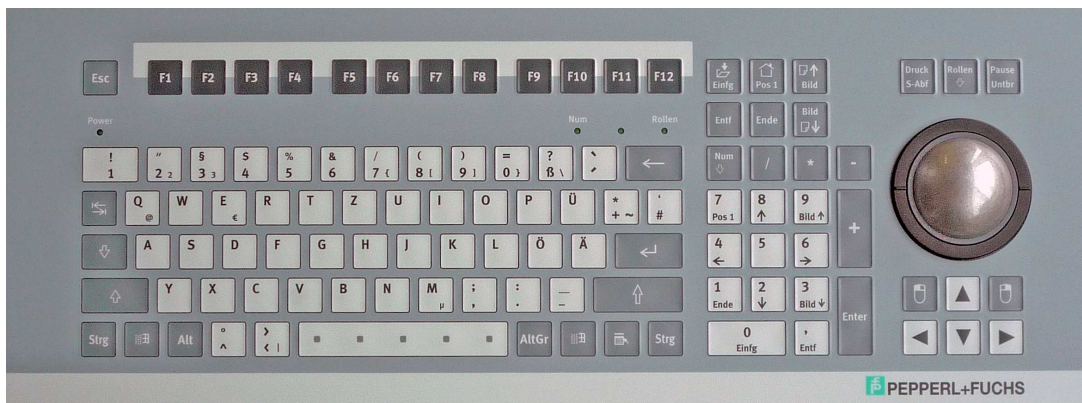



### EXTA3-\*\*-\*-K8\*

General data	
Type	Keyboard with optical trackball
Compatible components	SK-PC-D2-UU1-10-HS
Power supply	
Rated voltage	Ex i, via data line
Indicators/operating elements	
Keyboard	105 input keys Keyboard layout: US International (other keyboard layouts on request)
Trackball	
Diameter	50 mm
Material	Phenolic, polyester, epoxy resin (gray)
Driver	Microsoft Mouse®, USB
Interface	
Interface type	USB
Directive conformity	
Electromagnetic compatibility	
Directive 2014/30/EU	EN 61326-1:2013
Explosion protection	
Directive 2014/34/EU	IP66 (front) Type 4X
Conformity with standards	
Degree of protection	IP66 (front) Type 4X

547507 2019-09

Ambient conditions	
Operating temperature	-20 °C ... 50 °C (-4 °F ... 122 °F)
Storage temperature	-20 °C ... 70 °C (-4 °F ... 158 °F)
Relative humidity	Max. 85 %, not condensing (48 h endurance test)

Mechanical data	
Material	Anodized aluminum, polyester film
Weight	1.2 kg
Dimensions	Desktop housing: 559.3 mm x 254.6 mm x 44.5 mm (22.02 x 10.02 x 1.75) Panel mounting: 491.4 mm x 186.8 mm x 45 mm (19.35 x 7.35 x 1.77)
Opening dimensions	483 mm x 178.2 mm (19.01 x 7.01)
Cable length	1.8 m
Note	The limited energy barrier (SK-PC-D2-UU1-10-HS) is required when using this product.

Data for use in hazardous areas		
Certificate	PF II CERT 1918X	
Marking	 II 3GEx ic IIC T4 Gc  II 3D EX ic IIB T135 °C Dc	
Input		
Voltage	$U_i$	5.4 VDC
Current	$i_i$	240 mA
Internal capacitance	$C_i$	24 $\mu$ F
Internal inductance	$L_i$	Negligible

International approvals	
UL approval	cULus (E190294)
Approved for	<b>EXTA3-D2:</b> Class I Division 2 Groups A, B, C, D Class I Zone 2 Group IIC <b>EXTA3-D4:</b> Class I Division 2 Groups A, B, C, D Class II Division 2 Groups F, G Class III Class I Zone 2 Group IIC Class II Zone 22 Group IIIB Class III Zone 22 Group IIIA
Control Drawing	116-0357B

## 2.7 EXTA3-\*\*-\*-K9\*Keyboard

Keyboard with resistive touch pad mouse.

The function of the left and right mouse buttons is performed by two separate buttons below the touch pad.



### EXTA3-\*\*-\*-K9\*



General data	
Type	Keyboard with resistive touch pad mouse
Compatible components	SK-PC-D2-UU1-10-HS
Power supply	
Rated voltage	Ex i, via data line
Indicators/operating elements	
Keyboard	105 input keys Keyboard layout: US International (other keyboard layouts on request)
Touch pad	
Sensing principle	Resistive
Resolution	40 Pts./mm
Dimensions	66 mm x 50 mm
Driver	Microsoft Mouse®, USB
Interface	
Interface type	USB
Directive conformity	
Electromagnetic compatibility	
Directive 2004/108/EC	EN 61000-4-2: 2009, EN 61000-4-3: 2006 + A1: 2008, EN 61000-4-4: 2004, EN 61000-4-6: 2009, EN 55011: 2009, EN 61000-6-2: 2005, EN 61000-6-4: 2007, EN 61326-1: 2006

547507 2019-09

Conformity with standards	
Degree of protection	IP66 (front) Type 4X

Ambient conditions	
Operating temperature	-20 °C ... 50 °C (-4 °F ... 122 °F)
Storage temperature	-20 °C ... 70 °C (-4 °F ... 158 °F)
Relative humidity	Max. 85 %, not condensing (48 h endurance test)

Ambient conditions	
Material	Anodized aluminum, polyester film
Weight	1.2 kg
Dimensions	Desktop housing: 559.3 mm x 254.6 mm x 44.5 mm (22.02 x 10.02 x 1.75) Panel mounting: 491.4 mm x 186.8 mm x 45 mm (19.35 x 7.35 x 1.77)
Opening dimensions	483 mm x 178.2 mm (19.01 x 7.01)
Cable length	1.8 m
Note	The limited energy barrier (SK-PC-D2-UU1-10-HS) is required when using this product.

Data for use in hazardous areas		
Certificate	PF II CERT 1918X	
Marking	 II 3GEx ic IIC T4 Gc  II 3D EX ic IIB T135 °C Dc	
Input		
Voltage	$U_i$	5.4 VDC
Current	$i_i$	240 mA
Internal capacitance	$C_i$	24 µF
Internal inductance	$L_i$	Negligible
Directive conformity		
Directive 94/9/EC	EN 60079-0: 2009 EN 60079-11: 2007	

UL approval	cULus (E190294)
Approved for	<b>EXTA3-D2:</b> Class I Division 2 Groups A, B, C, D Class I Zone 2 Group IIC <b>EXTA3-D4:</b> Class I Division 2 Groups A, B, C, D Class II Division 2 Groups F, G Class III Class I Zone 2 Group IIC Class II Zone 22 Group IIIB Class III Zone 22 Group IIIA
Control Drawing	116-0357C

## 2.8 Accessories

An additional barrier is required if the EXTA3 keyboard is used as a stand-alone keyboard.

Model number	Description	Part number
SK-PC-D2-UU1-10-HS	<ul style="list-style-type: none"><li>• 1-channel or 2-channel non-incendive barrier for Division 2</li><li>• Can be mounted in Division 2/Zone 2</li><li>• USB or PS2 interface for Ex-rated keyboard or mouse</li></ul>	547054

## 3 Installation and Commissioning

### 3.1 Connecting the Keyboard Connection Cable



#### Note

For information about installation and connection in North America, see control drawing 116-0357C.



#### Caution!

Hazardous area

Energized non-intrinsically safe circuits may only be connected or disconnected outside the potentially explosive atmosphere.



#### Connecting the Keyboard to a PC Using the Keyboard Connection Cable

1.Connect the wires of the keyboard connecting cable as shown in the table below.

2.After connecting the keyboard, tighten the screws on the EXTA3 cover to a torque of 0.5 Nm.

#### Wire assignment for the keyboard and mouse (EXTA3-K \*)

<b>Output 1</b> Keyboard (field)	1+	V+	Power supply	Green
	2+	D+	Input/output	Brown
	3-	D-	Input/output	Gray
	4-	V-	Power supply	Yellow
<b>Output 2</b> Mouse (field)	5+	V+	Power supply	Red
	6+	D+	Input/output	White
	7-	D-	Input/output	Pink
	8-	V-	Power supply	Blue



#### Connecting the Keyboard to a PC Via SK-PC-D2-UU1-10-HS Barrier



#### Note

For further information, refer to our SK-PC-D2-UU1-10-HS manual and documentation at [www.pepperl-fuchs.com](http://www.pepperl-fuchs.com).

1.Insert the USB plugs of the keyboard cable into the USB connections of the barrier. Use the front USB connections labeled "field."

2.Insert the USB plugs of the supplied USB cables into the USB connections of the barrier. Use the front USB connections labeled "Host."

3.Insert the USB plugs of the supplied USB cables into two unused USB connections on the PC.



#### Establishing Equipotential Bonding



#### Warning!

Explosion hazard

#### Grounding via keyboard

Danger to life and serious property damage. The housing must always be connected to the protective conductor. Two options are available:

Connection via the cable shield of the connection cable

Installation in a metal housing that is connected to the PE

1. The shielding of the keyboard cable must be connected to the cable gland of the PC or the display unit (VisuNet) (see VisuNet manual). To do so, open the cable clamp (1) and remove the flexible cable conduit (2).

#### Open cable end of the keyboard

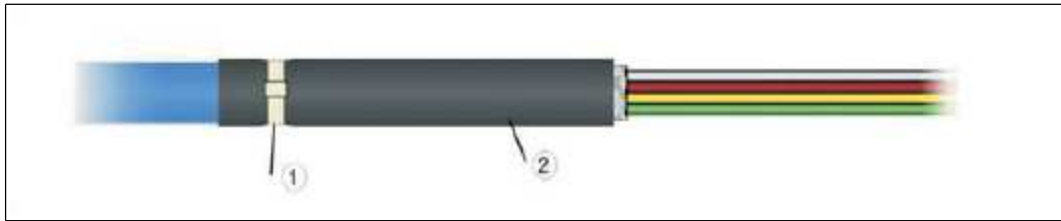

Figure 3.1(1) Cable clamp, (2) Flexible cable conduit

2. Install the keyboard in a metal housing that is connected to the PE.

## 3.2 Housing Design of the Keyboard

### Keyboard—Housing

There are various options for mounting the keyboards available.

1. Panel mounting (housing version -N)
2. Mounting the keyboard in a desktop housing (housing version -T)
3. Wall mounting (housing version -F)

This keyboard can be mounted using various mounting options

### Keyboard for Panel Mounting (Housing Version -N3)

#### Note

When installed in North America, the **EXTA3-D2-N3-K\*** variant is only suitable for use in the following areas:

- Class I, Division 2; Groups A, B, C, D; T5
- Class I, Zone 2; Group IIC; T5

The **EXTA3-D4-N3-K\*** variant is only suitable for use in the following areas:

- Class I, Division 2; Groups A, B, C, D; T5
- Class II, Division 2; Groups F, G; T5
- Class III
- Class I, Zone 2; Group IIC; T5
- Class II, Zone 22; Group IIIB
- Class III, Zone 22; Group IIIA



#### Danger!

Explosion hazard

Do not replace any components. Replacing a component may affect its suitability for Class I, Division 2 and Class II, Division 2. The devices must be installed in a suitable housing.



#### Caution!

Maximum ambient temperature

The devices are suitable for a maximum ambient temperature of -20 °C to 50 °C. The EXTA3-D2-\*\*-K8 variant is only suitable for an ambient temperature of 0 °C to 50 °C.



Dimensions for keyboard with panel mounting

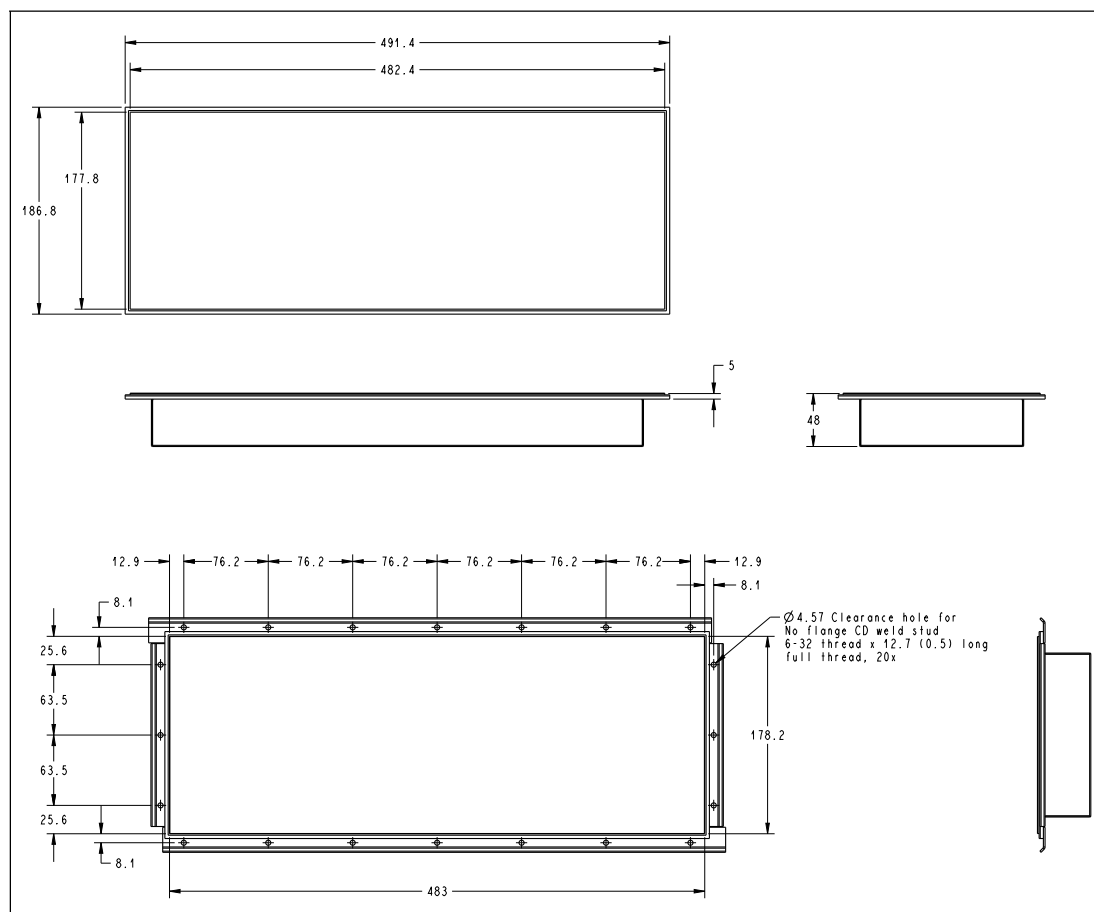

Figure 3.2



**Note**

Torque specifications

Tighten the screws for the EXTA3 keyboard and the housing interface to 0.7 Nm.

For the keyboard to be truly flush with the housing, the thickness of the housing must be at least 1.5 mm.

**Keyboard with desktop housing (housing version -T3, [e.g., for VisuNet])**



**Note**

When installed in North America, the **EXTA3-D2-T3-K\*** variant is only suitable for use in the following areas:

- Class I, Division 2; Groups A, B, C, D: T5
- Class I, Zone 2; Group IIC; T5

The **EXTA3-D4-T3-K\*** variant is only suitable for use in the following areas:

- Class I, Division 2; Groups A, B, C, D: T5
- Class II, Division 2; Groups F, G; T5
- Class III
- Class I, Zone 2; Group IIC; T5
- Class II, Zone 22; Group IIIB
- Class III, Zone 22; Group IIIA



**Caution!**

Maximum ambient temperature

The devices are suitable for a maximum ambient temperature of -20 °C to 50 °C. The EXTA3-D2-\*\*-K8 variant is only suitable from 0 °C to 50 °C.

Keyboard dimensions

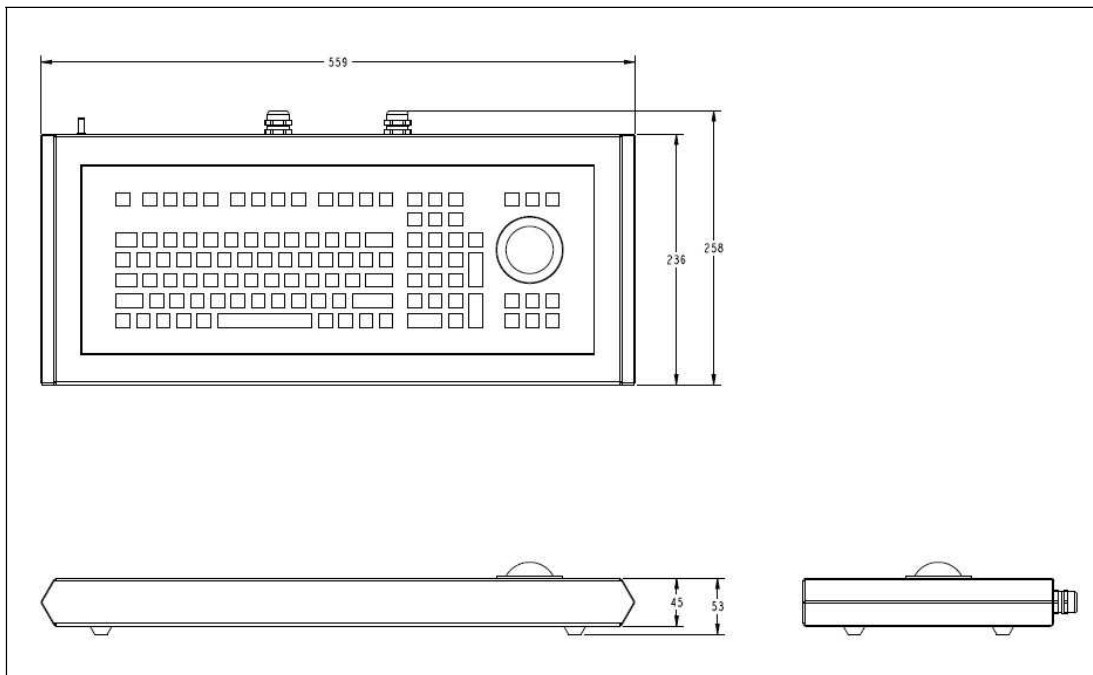

Figure 3.3



**Note**

The cables can be removed from the circuit board to make it easier to mount the keyboard. After mounting the keyboard, reconnect all cables properly, including the PE cable.

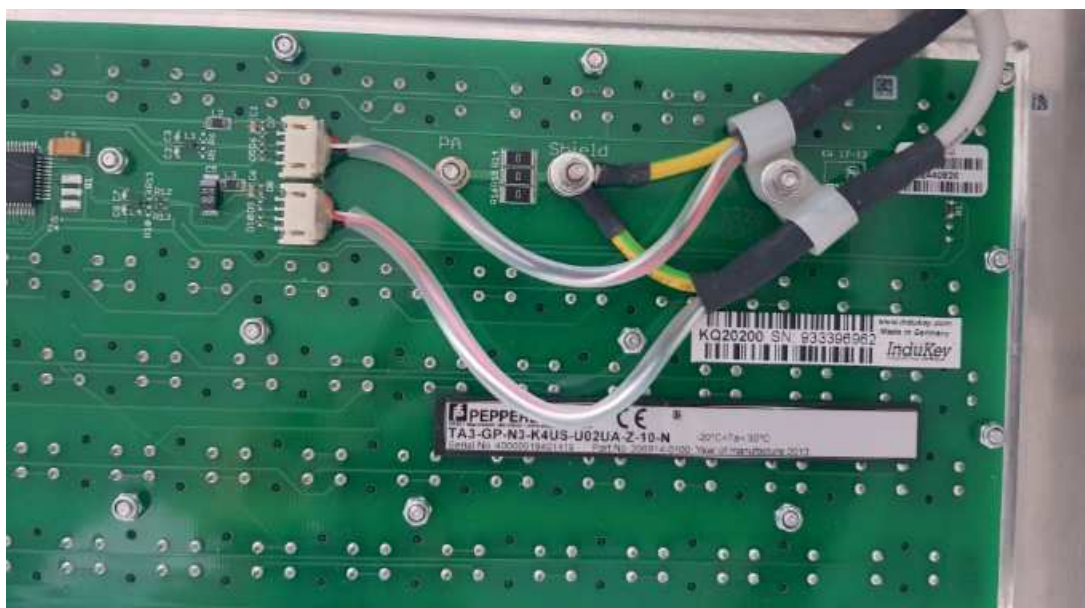

Figure 3.4

Tighten the protective earth to a torque of 0.15 Nm.

Tighten the cable clamp to a torque of 0.3 Nm.

### Keyboard for Wall Mounting (Housing Version -F)

Keyboard dimensions

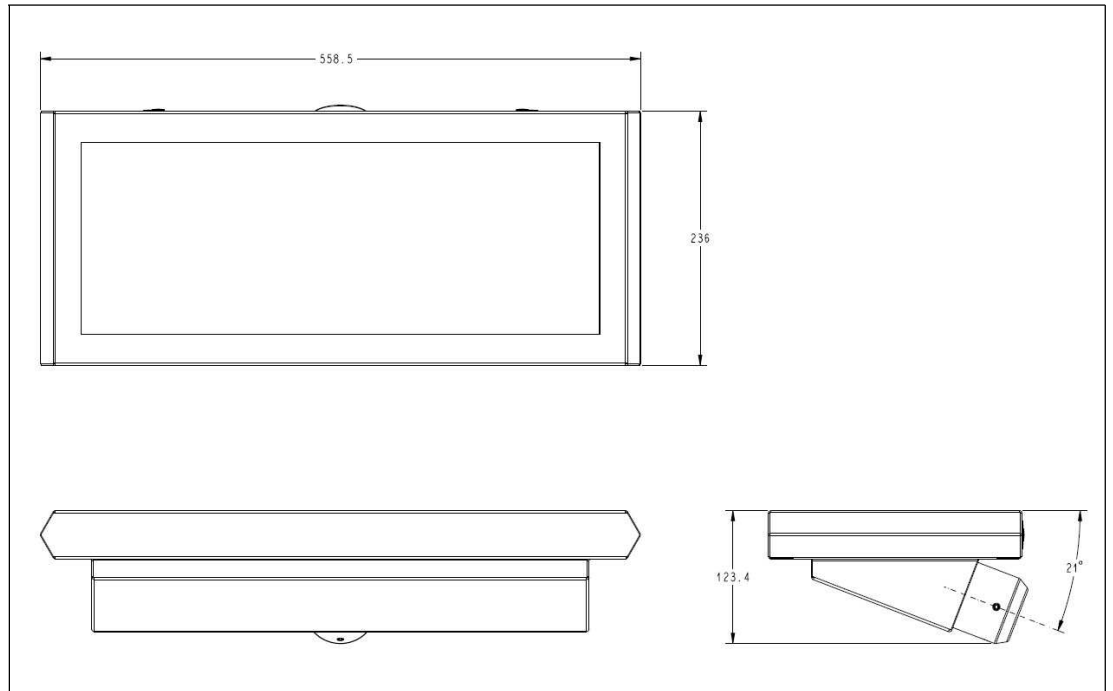

Figure 3.5 Standard housing with option F-R, prepared for pipe mounting

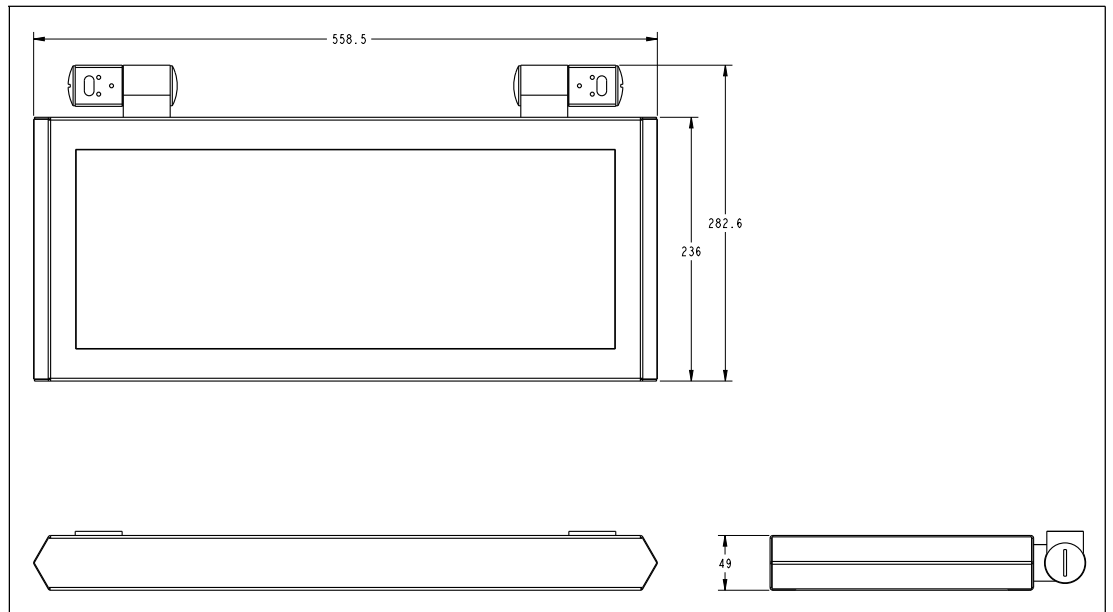

Figure 3.6 Standard housing with option F-C, with mounting adaptor

### 3.3 Replacing an EXTA3-K\* keyboard

Assembly, commissioning, operation, maintenance, and dismantling of any device may only be carried out by trained, qualified personnel.



**Caution!**

Fault / Complete Failure

Devices or any connected facilities or systems may develop a fault or fail completely. Consider the ESD safety measures.

**3.3.1 Dismounting an EXTA3-K\* keyboard**



**Dismounting a keyboard**

1. Separate the silicon joint between housing and keyboard. Use a sharp-edged tool, for example, a knife or a scalpel.
2. Open the bottom plate.
3. Remove the cables from the board: Remove the cables (1). Detach the PE connector (2). Detach the cable clamp (3). When reconnecting the PE connector, tighten the lock nut to a torque of 0.3 Nm.

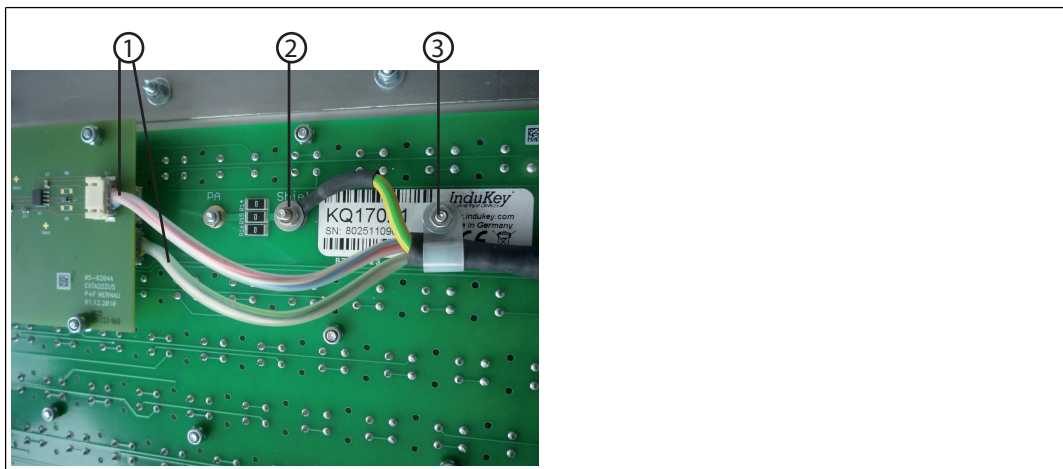

4. Remove the mounting rail of the keyboard. Remove the lock nuts. Remove the rails.



5. Remove the keyboard through the front of the housing.



### 3.3.2 Attaching EXTA3-K\*Keyboard



#### Attaching the Keyboard

1. Remove the cover plate of the keyboard.
2. Replace the eight distance bolts with eight lock nuts. Tighten the lock nuts to a torque of 0.3 Nm.
3. Remove the connection cable of the keyboard. See chapter 3.3.
4. From the front, place the keyboard correctly in the housing. See chapter 3.3 (In reverse order).
5. From the rear, place the mounting rails on the keyboard and secure them with the new lock nuts provided. Tighten one lock nut on each rail but ensure that the keyboard can still be moved. Center the keyboard. Tighten all the lock nuts to a torque of 0.4 Nm using a suitable tool.
6. Attach the cable clamp. Depending on the keyboard variant, one or two cables are available.

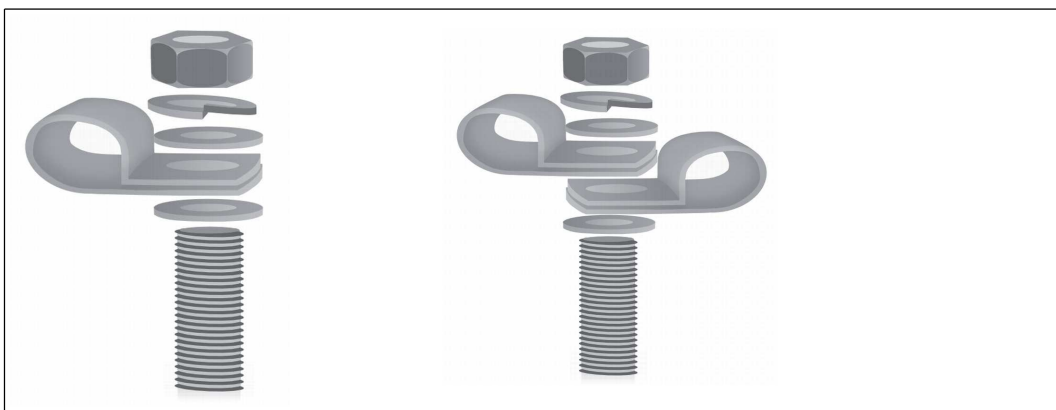

7. Attach the PA cable. Depending on the keyboard variant, one or two cables are available.

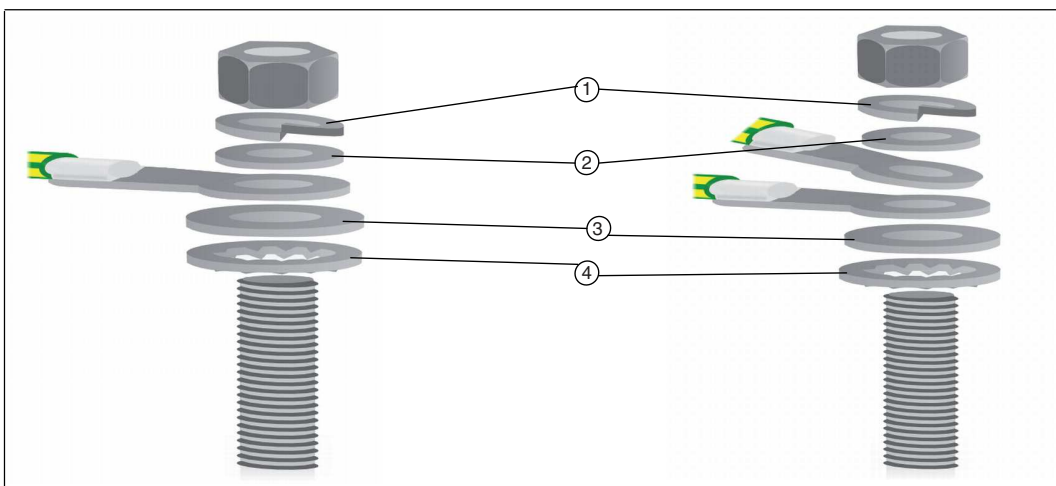

- 1 Spring washer M3
- 2 Washer M3
- 3 Washer M4
- 4 Toothed lock washer M4

8. Connect the cables to the circuit board.

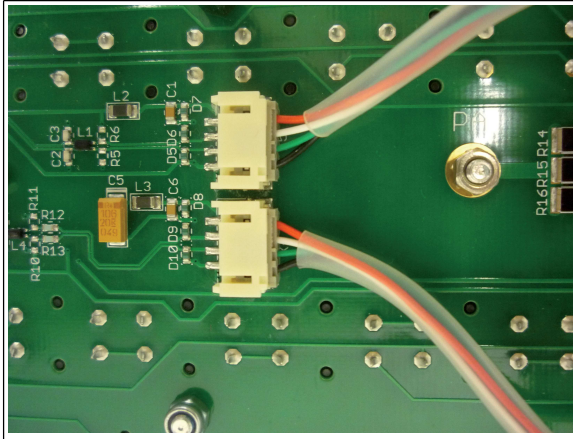

9. Close the base plate.

10. To ensure GMP compatibility, properly apply silicone to the gap on the keyboard.

## 4 Appendix

### 4.1 Chemical Resistance of Keyboard Foil

The keyboard foil is manufactured from a biaxially aligned polyester-based material and therefore has a greater resistance to solvents. The foil is stronger and more durable than other standard foils used on keyboards and front panels, such as polycarbonate and PVC.

The keyboard foil is resistant against the following substances: (Test method: DIN42115):

- Alcohols
- Dilute acids
- Dilute alkalis
- Esters
- Hydrocarbons
- Household cleaning

### 4.2 Anti Microbial Resistance of Keyboard Foil

The foil passed the anti microbial effectiveness tested with (Test method: AATCC Test Method 100):

- Staphylococcus aureus (MRSA)
- Escherichia coli 0157
- Listeria monocytogenes
- Pseudomonas aeruginosa
- Salmonella enteritidis
- Bacillus cereus
- Streptococcus faecalis
- Klebsiella pneumoniae
- Aspergillus niger
- Penicillium purpurogenum
- Phoma violacea
- Saccharmyces cerevisiae

### 4.3 Type Code

Keyboard type	Degree of protection	Housing version	Keyboard and mouse type	Keyboard layout	Connection type	Housing connection
Keyboard type						
<b>EXTA3</b>	Keyboard for hazardous areas					
	<b>Degree of protection</b>					
	<b>-A1</b>	ATEX II 3GD, Zone 2 & 22				
	<b>-D2</b>	Class I Division 2, Class I Zone 2				
	<b>-D4</b>	Class I/II Division 2, Class III ad Class I Zone 2, Class II/III Zone 22				
		<b>Housing version</b>				
	<b>-N3</b>	Panel mounting/without housing				
	<b>-T3</b>	Desktop housing, stainless steel				
	<b>-F</b>	Housing with various mounting options, stainless steel				
		<b>Keyboard and mouse type</b>				
		<b>-K1</b>	Membrane keyboard without mouse			
		<b>-K3</b>	Membrane keyboard with 50 mm trackball (mechanical)			
		<b>-K4</b>	Membrane keyboard with touch pad (capacitive)			
		<b>-K6</b>	Membrane keyboard with joystick			
		<b>-K8</b>	Membrane keyboard with 50 mm trackball (optical)			
		<b>-K9</b>	Film keyboard with touch pad (resistive)			
			<b>Keyboard layout</b>			
			<b>-US</b>	US international keyboard layout		
			<b>-DE</b>	German keyboard layout		
			<b>-FR</b>	French keyboard layout		
				<b>Connection type</b>		
				<b>-CF</b>	Cable ends with wire end ferrules	
					<b>Housing connection</b>	
					Z	No housing connection
					C	Hinged housing connection, 90°–180° tilt, stainless steel, 304 SS housing
					R	Housing connection with preparation for 48 mm stainless steel pipes (pedestals/wall brackets)



# Your automation, our passion.

## Explosion Protection

- Intrinsic Safety Barriers
- Signal Conditioners
- FieldConnex® Fieldbus
- Remote I/O Systems
- Electrical Ex Equipment
- Purge and Pressurization
- Industrial HMI
- Mobile Computing and Communications
- HART Interface Solutions
- Surge Protection
- Wireless Solutions
- Level Measurement

## Industrial Sensors

- Proximity Sensors
- Photoelectric Sensors
- Industrial Vision
- Ultrasonic Sensors
- Rotary Encoders
- Positioning Systems
- Inclination and Acceleration Sensors
- Fieldbus Modules
- AS-Interface
- Identification Systems
- Displays and Signal Processing
- Connectivity

### Pepperl+Fuchs Quality

Download our latest policy here:

[www.pepperl-fuchs.com/quality](http://www.pepperl-fuchs.com/quality)

