



APPLICATIONS

Collecting of leachate in storage tanks, pumping of industrial waste water from wells or collecting reservoirs.

The ATEX pumps in conformity with 2014/34/EU Directive can be installed in potentially explosive atmospheres according to the marking explained hereafter.

FEATURES

- Open impeller in cast iron to avoid obstruction from mud and other suspended small solids.
- Electric pumps produced with 5 m electric cable included.
- Temperature of pumped liquid: max +40 °C.
- Available the version for permanent immersion in hydrocarbons (our ID EX series).

MOTOR

- 2 poles asynchronous motor, 50 Hz, 2850 rpm.
- Class F insulation.
- IP68 protection.
- Working voltage: single-phase 230 V, three-phase 400 V.

ACCESSORIES

- Control panel.
- Intrinsically safe module with ATEX supply circuit.
- ATEX level regulator with 5, 10 or 20 m of electric cable.
- ATEX (or ID ATEX) electronic level transmitter.
- Electric cable to combine according to the chosen version and the liquid to pump.

Technical specifications

Pump type	Motor		Max current		Outlet Ø	Delivery																	
	HP	kW	230 V 1~	400 V 3~		l/min	0	50	100	150	200	250	300	350	400	450	500	550	600	650	700	750	
			A	A			m³/h	0	3	6	9	12	15	18	21	24	27	30	33	36	39	42	45
DERBY EX 50	0,5	0,37	4,3	1,5	2"	Manometric head (m)	8	7,3	6,5	6	5,5	4,7	3,7	3	2	1							
DERBY EX 75	0,75	0,55	5,1	1,7			9,5	9	8,2	7,5	6,8	6	5,2	4,2	3,2	2	1						
DERBY EX 100	1	0,75	7	2,5			11,5	10,9	10,2	9,6	9	8,2	7,5	6,6	5,8	5	4	3	2	1			
DERBY EX 150	1,5	1,1	10,5	3,1			13,1	12,5	12	11,5	10,8	10	9,1	8,2	7,3	6,5	5,5	4,3	3,2	2,1	1		
DERBY EX 200	2	1,5	12,5	3,8			15	14,5	13,9	13,2	12,5	11,9	11	10,2	9,5	8,3	7,2	6,2	5,1	4	2,4	1	

Performance curves

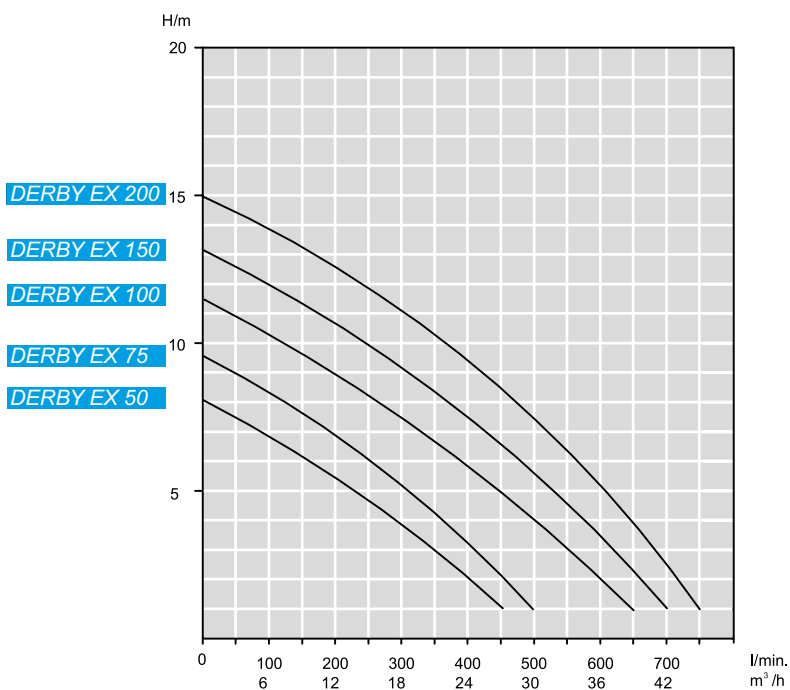

Dimensions and weights

Pump type	Dimensions		Weight
	mm		
	A	B	kg
DERBY EX 50	445	230	16,7
DERBY EX 75	445	230	16,7
DERBY EX 100	475	230	18,1
DERBY EX 150	505	250	20,6
DERBY EX 200	520	250	21,8

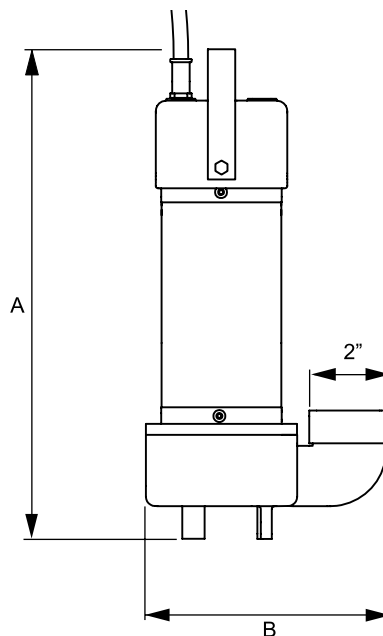

ATEX marking

II	<i>Group of apparatus - equipment for surface plants.</i>
2G	<i>Category - equipment compatible to be installed in potentially explosive atmospheres with gas, steams and vapors (area 1); this equipment is suitable for area 1 and area 2.</i>

ATEX drainage electric pumps protection

Ex	<i>Protection against explosions.</i>
eb	<i>Type of protection applied to electrical motor – increased safety “e”, level “b” – type of protection applied to electrical apparatus in which additional measures are applied so as to give increased safety against the possibility to excessive temperature and of the occurrence of ark and sparks in normal service or under specified abnormal conditions.</i>
h	<i>Type of protection applied to hydraulic part – constructional safety “k” – ignition protection where constructional measures are applied so as to protect against the possibility of ignition from hot surfaces, sparks and adiabatic compression generated by moving parts</i>
mb	<i>Type of protection applied to connection facility to external circuits – encapsulation “m”, level “b” – type of protection whereby parts that are capable of igniting an explosive atmosphere by either sparking or heating are fully enclosed in a compound or other non-metallic enclosure with adhesion in such a way as to avoid ignition of a dust layer or explosive atmosphere under operating or installation conditions</i>
ob	<i>Type of protection applied to electrical motor – liquid immersion “o”, level “b” – type of protection in which the electrical equipment or parts of the electrical equipment are immersed in a protective liquid in such a way that an explosive gas atmosphere which may be above the liquid or outside the enclosure cannot be ignited.</i>
IIC	<i>Subgroup of gas: equipment compatible to be installed with all combustible gas.</i>
T5/T6	<i>Class temperature – maximum temperature of the equipment 100 °C . When the mark is T6 the maximum temperature of the machine is 85 °C.</i>
Gb	<i>Protection level of equipment compatible to be installed in potentially explosive atmospheres with combustible gas - level b.</i>